

2.2 Assembly Drawing

2.2.1 Structure Drawing of SICC-W Single Unit

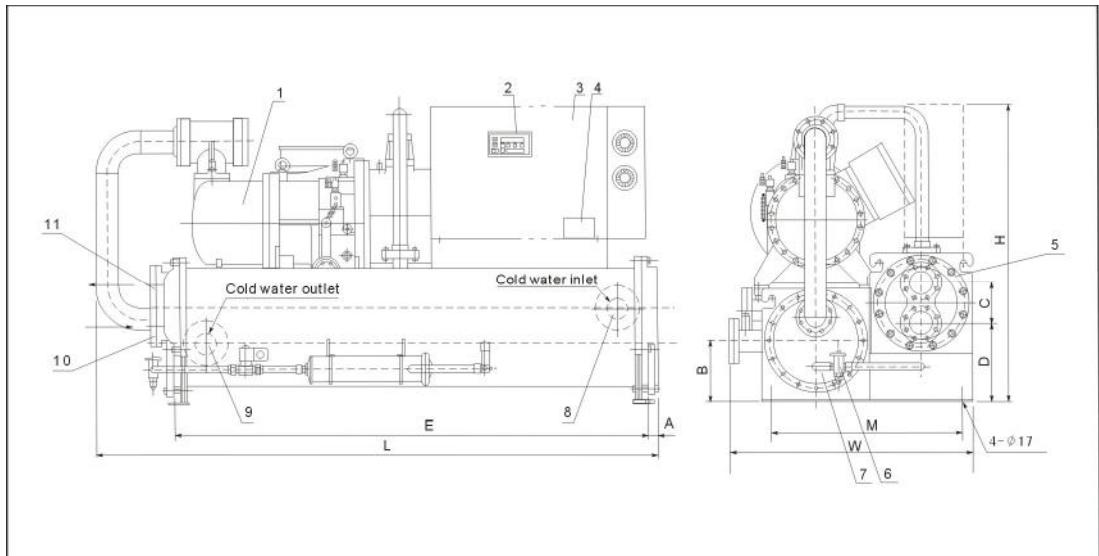

Names of Parts:

- | | | |
|--------------------------|--------------------------|---------------------------|
| 1. Compressor | 2. PLC control panel | 3. Electrical control box |
| 4. Nameplate of the unit | 5. Condenser | 6. Expansion valve |
| 7. Evaporator | 8. Cold water inlet | 9. Cold water outlet |
| 10. Cooling water inlet | 11. Cooling water outlet | |

Picture 2-3: Structure Drawing of SICC-W Single Unit

2.2.2 Structure Drawing of SICC-W Double Unit

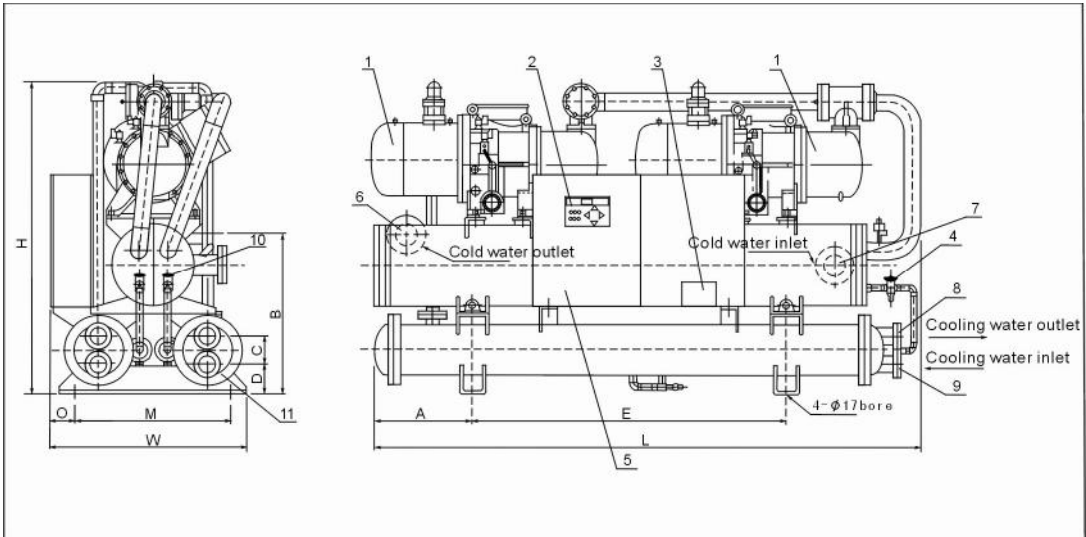

Names of Parts:

- | | | |
|---------------------|---------------------------|--------------------------|
| 1. Compressor | 2. PLC control panel | 3. Nameplate of the unit |
| 4. Expansion valve | 5. Electrical control box | 6. Cold water outlet |
| 7. Cold water inlet | 8. Cold water outlet | 9. Cold water inlet |
| 10. Evaporator | 11. Condenser | |

Picture 2-4: Structure Drawing of SICC-W Double Unit