



Water-cooled Central Water Chiller

SICC-450WD-R3



Refer carefully to this manual before operation.

SICC-W Series

■ Coding Principle

SICC - xxxWx - R3

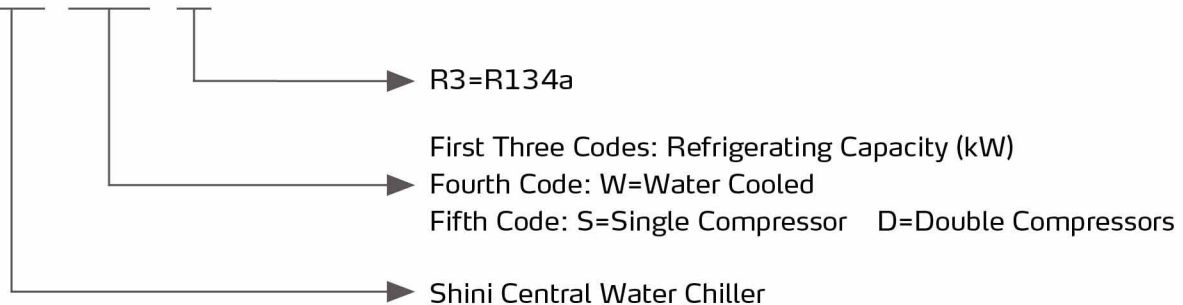

■ Features

- Brand semi-close double-screw compressor and long service-life of bearing ensure long time operation, and it is equipped with high-efficient motor that gives compressor high efficiency.
- Step-less compressor can achieve a cooling output range of 50~100% with each compressor and realize stable cooling output.
- The condenser and evaporator both can meet the requirement of national standard, with high-efficient heat transfer effect, convenient service and maintenance.
- Standard equipped RS485 communication function that can achieve machine unit's real-time control and monitor.
- Equipped with programmable logical controller to control via panel for convenient adjustment.
- The error check function and error recording function can analyze the causes for improvement.
- Standard equipped with high and low pressure switch, fusible plug, overload protector, coil overheat protector, exhaust air overheat protection, cooling water overheat and large temperature deviation protection.

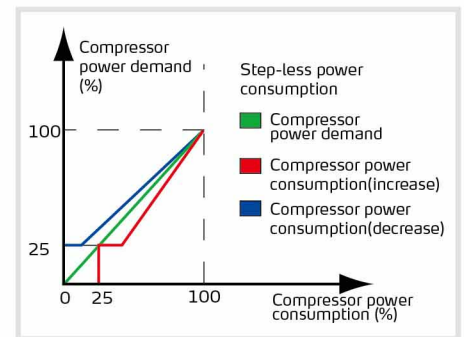

Step-less loading capacity

■ Application

It is used for mould's cooling to reduce product's molding cycle, and it's applicable to cooling devices to ensure the temperature maintained under normal value, or other industrial areas need cooling.

■ Working Principle

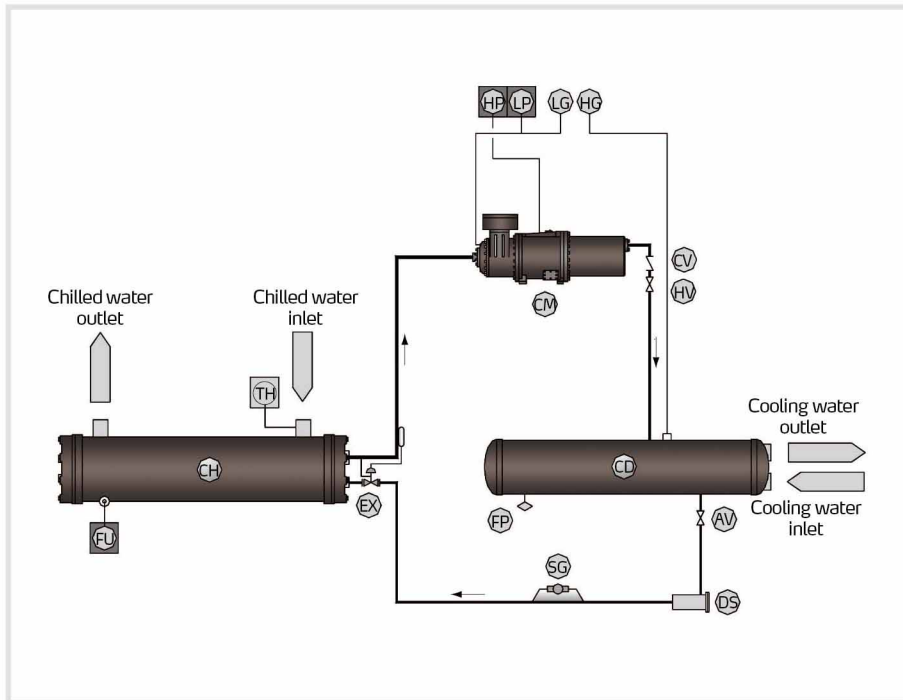

One Compressor

Sign	Name	Amount Remark
CM	Compressor	1
CD	Condenser	1
CH	Evaporator	1
EX	Expansion valve	1
FP	Fusible plug	1
AV	Angle valve	1
DS	Drier filter	1
SG	Refrigerant indicator	1
CV	Contrary stop value	1
HV	High pressure valve	1
HG	High pressure gauge	1
LG	low pressure gauge	1
HP	High pressure switch	1
LP	Low pressure switch	1
TH	Thermo switch	1
FU	Anti-freezing switch	1

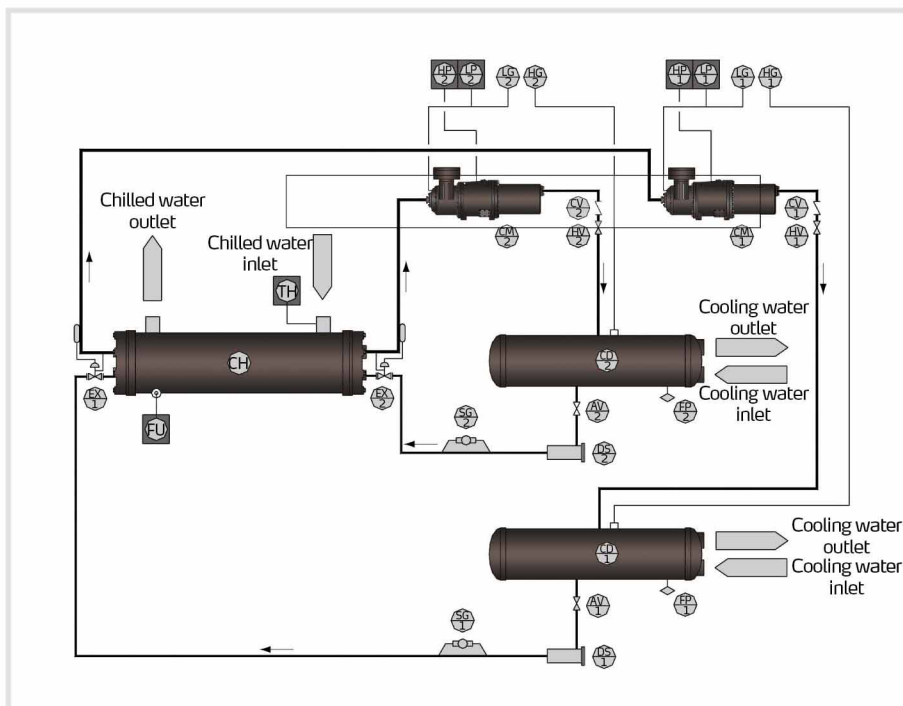

Two Compressors

Sign	Name	Amount Remark
CM1-2	Compressor	2
CD1-2	Condenser	2
CH	Evaporator	1
EX1-2	Expansion valve	2
FP1-2	Fusible plug	2
AV1-2	Angle valve	2
DS1-2	Drier filter	2
SG1-2	Refrigerant indicator	2
CV1-2	Contrary stop value	2
HV1-2	High pressure valve	2
HG1-2	High pressure gauge	2
LG1-2	low pressure gauge	2
HP1-2	High pressure switch	2
LP1-2	Low pressure switch	2
TH	Thermo switch	1
FU	Anti-freezing switch	1

SICC-W Series

Outline Drawings

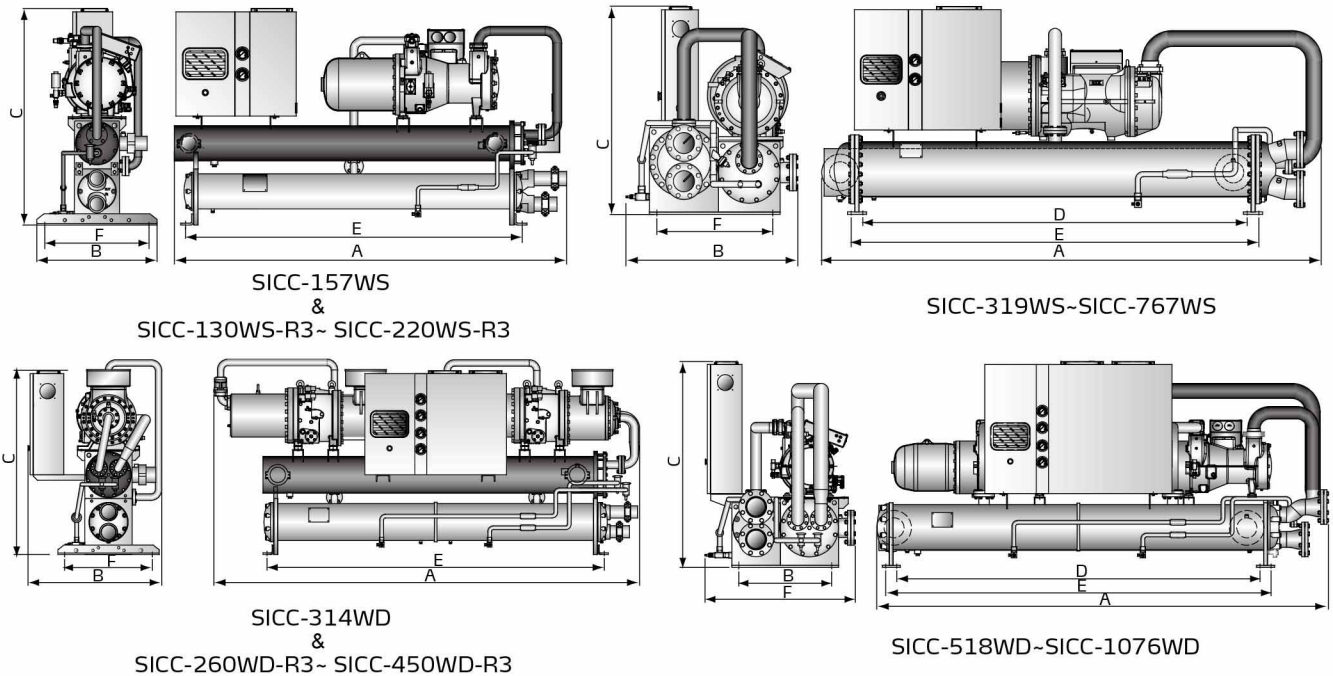

Specifications (R22)

Item	Model SICC-	157WS	319WS	413WS	538WS	611WS	767WS	
Cooling Capacity	kW ¹⁾	157	319	413	538	611	767	
	kW ²⁾	128	251	330	430	488	610	
Power Source	—	3 ϕ 380V 50Hz						
Power Consumption	kW	35.4	68	100.3	120.9	125.9	156.7	
Operation Current	A	63	122	179	216	225	280	
Start-up Current	A	269	516	579	757	586	805	
Power Adjustment	—	Capacity level 4 control						
Filling Quantity	L	11	17	17	21	21	25	
	Type	KL320SH						
Refrigerant	—	R22						
Evaporator	Type	—			U type tube-in-shell style		Tube-in-shell style	
	Process Flow	m ³ /hr	27.0	54.9	71.0	92.5	105.0	131.9
	Pressure Loss	kPa	48	54	63	63	66	80
	Pipe Coupler		ϕ 3"Clamp	ϕ 4"Clamp	ϕ 4"Clamp	DN125	DN150	DN150
Condenser	Type	—						
	Cooling Flow	m ³ /hr	35.1	71.3	92.3	120.3	136.6	171.5
	Pressure Loss	kPa	20	30	45	45	45	58
Pipe Coupler		ϕ 3"Clamp	ϕ 4"Clamp	ϕ 4"Clamp	DN125	DN150	DN150	
Unit Dimensions	A	mm	2600	3050	3350	3450	3400	3800
	B	mm	750	1150	1250	1250	1350	1400
	C	mm	1500	1370	1450	1500	1650	1700
Installing Dimensions	D	mm	—	2390	2620	2620	2620	2920
	E	mm	2100	2550	2780	2780	2780	3080
	F	mm	650	600	670	790	870	920
Net Weight	kg	1220	1770	1900	2350	2600	3130	
Operating Weight	kg	1370	1970	2150	2650	2900	3480	
Unit Conversion		1 kW = 860 kcal/hr		1 RT = 3,024 kcal/hr		10,000 Btu/hr = 2,520 kcal/hr		



■ Specifications (R22)

Model		SICC-314WD	SICC-518WD	SICC-638WD	SICC-706WD	SICC-826WD	SICC-1076WD	
Refrigeration Capacity	kW ¹⁾	314	518	638	706	826	1076	
	kW ²⁾	256	408	502	578	660	860	
Power Source	—	3Φ 380V 50Hz						
Power Consumption	kW	70.8	119.2	136.0	162.6	200.6	241.8	
Power Consumption	A	126	213	243	291	359	432	
Operation Current	A	332	530	638	707	758	973	
Power Adjustment	—	8 steps capacity control						
Refrigerant Filling Quantity	L	22	26	34	34	34	42	
	Type	KL320SH						
Refrigerant		R22						
Evaporator	Type	—	U type tube-in-shell style			Tube-in-shell style		
		m ³ /hr	54.0	89.1	109.8	121.4	142.1	185.0
	Pressure Loss	kPa	60	63	66	66	66	80
	Pipe Coupler		Φ4"Clamp	DN125	DN150	DN150	DN150	DN200
Condenser	Type	—	Tube-in-shell style					
	Cooling Flow	m ³ /hr	70.2	115.8	142.7	157.9	184.7	240.6
	Pressure Loss	M	40	40	57	57	57	64
	Pipe Outlet		Φ4"Clamp	DN125	DN150	DN150	DN150	DN200
Unit Dimensions	A	mm	3180	3300	3900	3950	4000	4300
	B	mm	1050	1150	1300	1350	1450	1500
	C	mm	1700	1550	1600	1650	1650	1700
Installing Dimensions	D	mm	—	2620	2920	2920	2920	3190
	E	mm	2700	2780	3080	3080	3080	3350
	F	mm	650	670	870	920	980	1030
Net Weight	kg	2010	2610	3300	3700	3880	4350	
Operating Weight	kg	2210	2910	3600	4200	4380	4900	
Unit Conversion		1 kW = 860 kcal/hr		1 RT = 3,024 kcal/hr		10,000 Btu/hr = 2,520 kcal/hr		

- Notes: 1) Cooling capacity is measured based on the flow of 0.172m³/(h.kW) and the outlet temperature 15°C/59°F of chilled water under the temperature of 30°C/86°F and flow of 0.215m³/(h.kW) of cooling water.
- 2) Cooling capacity is measured based on the flow of 0.172m³/(h.kW) and the outlet temperature 7°C/44.6°F of chilled water under the temperature of 30°C/86°F and flow of 0.215m³/(h.kW) of cooling water.
- 3) Machine operation conditions: outlet chilling water temperature is at 7~25°C, inlet chilling water temperature is at 19~33°C, For special requirements, the machine can be customized.
- 4) The noise level is tested at 1m in front of and 1.5m above the machine.
- 5) As per application needs, stepless compressor output capacity adjusting function can be optionally available.

SICC-W Series

Specifications(R134a)

Model SICC-		130WS-R3	188WS-R3	220WS-R3	260WD-R3	380WD-R3	450WD-R3	
Refrigeration Capacity	kW ¹⁾	130	188	220	260	380	450	
	kW ²⁾	104	150	176	208	300	351	
Power Source	—	3 ϕ 400V 50Hz						
Power Consumption	kW	24	35.8	40.9	48	71.6	81.8	
Operation Current	A	41.5	60	69	83	120	138	
Start-up Current	A	310	480	600	351.5	540	669	
Power Adjustment	—	Step-less capacity control						
	Filling Quantity	L	7	14	16	14	28	32
	Type	—	HBR-B08					
refrigerant capacity	kg	22	26	32	44	52	64	
	lb	48.5	57.3	70.5	97	114.6	141.1	
Evaporator	Type	—	Tube-in-shell style					
	Process Flow	m ³ /hr	22	32	37.5	44	64	75
	Pressure Loss	kPa	46	50	52	58	63	63
	Pipe Coupler		ϕ 3"Clamp	ϕ 3"Clamp	ϕ 3"Clamp	ϕ 4"Clamp	ϕ 5"Clamp	ϕ 5"Clamp
Condenser	Type	—	Tube-in-shell style					
	Cooling Flow	m ³ /hr	26.5	38.5	45	53	77	90
	Pressure Loss	kPa	20	20	30	40	40	60
	Pipe Outlet		2.5"PT Female	3.0"PT Female	3.0"PT Female	2.5"PT Female	3.0"PT Female	3.0"PT Female
Unit Dimensions	A	mm	2490	2650	2780	2850	3110	3250
	B	mm	750	850	850	1075	1125	1125
	C	mm	1525	1655	1670	1570	1750	1750
Installing Dimensions	D	mm	—	—	—	—	—	—
	E	mm	1100	1266	1327	1260	1467	1467
	F	mm	540	640	640	798	878	878
Net Weight	kg	940	1200	1260	1860	2340	2530	
Operating Weight	kg	1040	1300	1360	2060	2590	2800	
Unit Conversion		1 kW = 860 kcal/hr 1 RT = 3,024 kcal/hr 10,000 Btu/hr = 2,520 kcal/hr						

- Notes: 1) Cooling capacity is measured based on the flow of 0.172m³/(h.kW) and the outlet temperature 15°C/59°F of chilled water under the temperature of 30°C/86°F and flow of 0.215m³/(h.kW) of cooling water.
2) Cooling capacity is measured based on the flow of 0.172m³/(h.kW) and the outlet temperature 7°C/44.6°F of chilled water under the temperature of 30°C/86°F and flow of 0.215m³/(h.kW) of cooling water.
3) Machine operation conditions: outlet chilling water temperature is at 7~25°C, inlet chilling water temperature is at 19~33°C, For special requirements, the machine can be customized.
4) The noise level is tested at 1m in front of and 1.5m above the machine.

Shini Group

Addr: No. 23, Minhe St., Shulin Dist.,
New Taipei, Taiwan

Tel: +886 2 2680 9119

Fax: +886 2 2680 9229

Email: shini@shini.com

Factories:

- Taiwan
- Dongguan
- Pinghu
- Ningbo
- Chongqing
- Pune